



TEXTURA

# EsPizarra

F<sup>r</sup>Ardoise — P<sup>t</sup>Pizarra — E<sup>n</sup>Slate — I<sup>t</sup>Pizarra



# EsColores

<sup>FR</sup>Couleurs — <sup>PT</sup>Cores — <sup>EN</sup>Colours — <sup>IT</sup>Colori

## Standard

Blanco  
RAL 9003



Pergamo  
RAL 1013

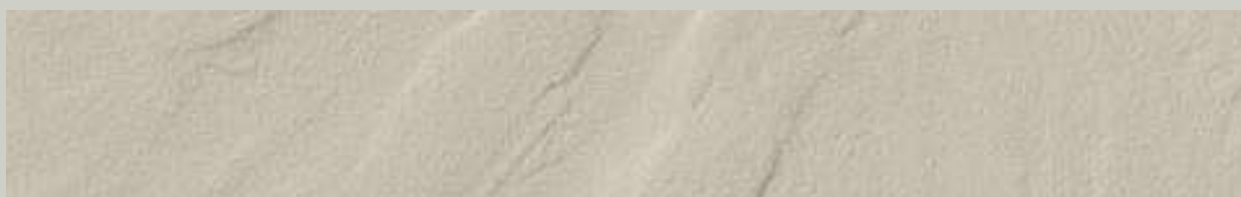

Arena  
RAL 1019



Cemento  
RAL 7040



Musgo  
RAL 7030

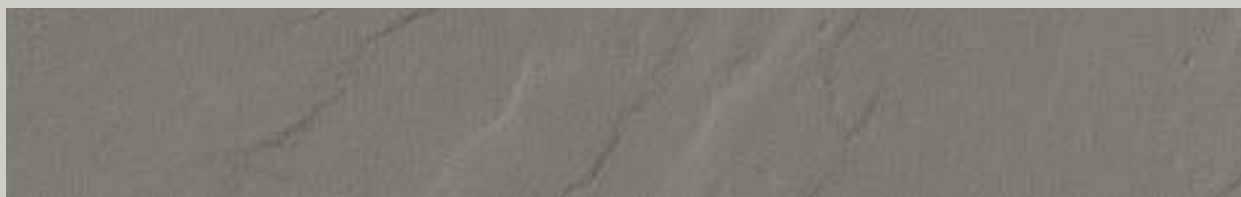

Grafito  
RAL 7016

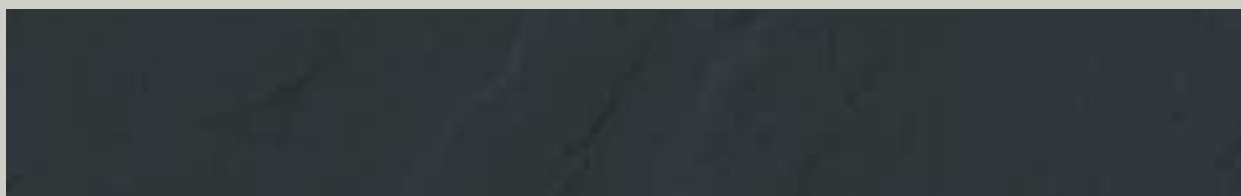

<sup>ES</sup>Pizarra — <sup>FR</sup>Ardoise — <sup>PT</sup>Pizarra — <sup>EN</sup>Slate — <sup>IT</sup>Pizarra

<sup>ES</sup> Esta nueva textura es una lograda mezcla de piedra y pizarra natural. Los detalles le dan un toque elegante.

<sup>FR</sup> Cette nouvelle texture élégante, est un mélange réussi des finitions pierre et ardoise naturelle.

<sup>PT</sup> Esta nova textura é uma perfeita mistura do acabamento pedra e pizarra natural. Os detalhes dão-lhe um toque elegante.

<sup>EN</sup> Texture consisting of a combination of natural stone and slate, with a linear and discreet customizable drain available in various colors, adding modernity and elegance to our bathroom.

<sup>IT</sup> Questa nuova struttura non è che una miscela tra la roccia e la ardesia naturale. I piccoli dettagli della rifinitura conferiscono eleganza al prodotto.

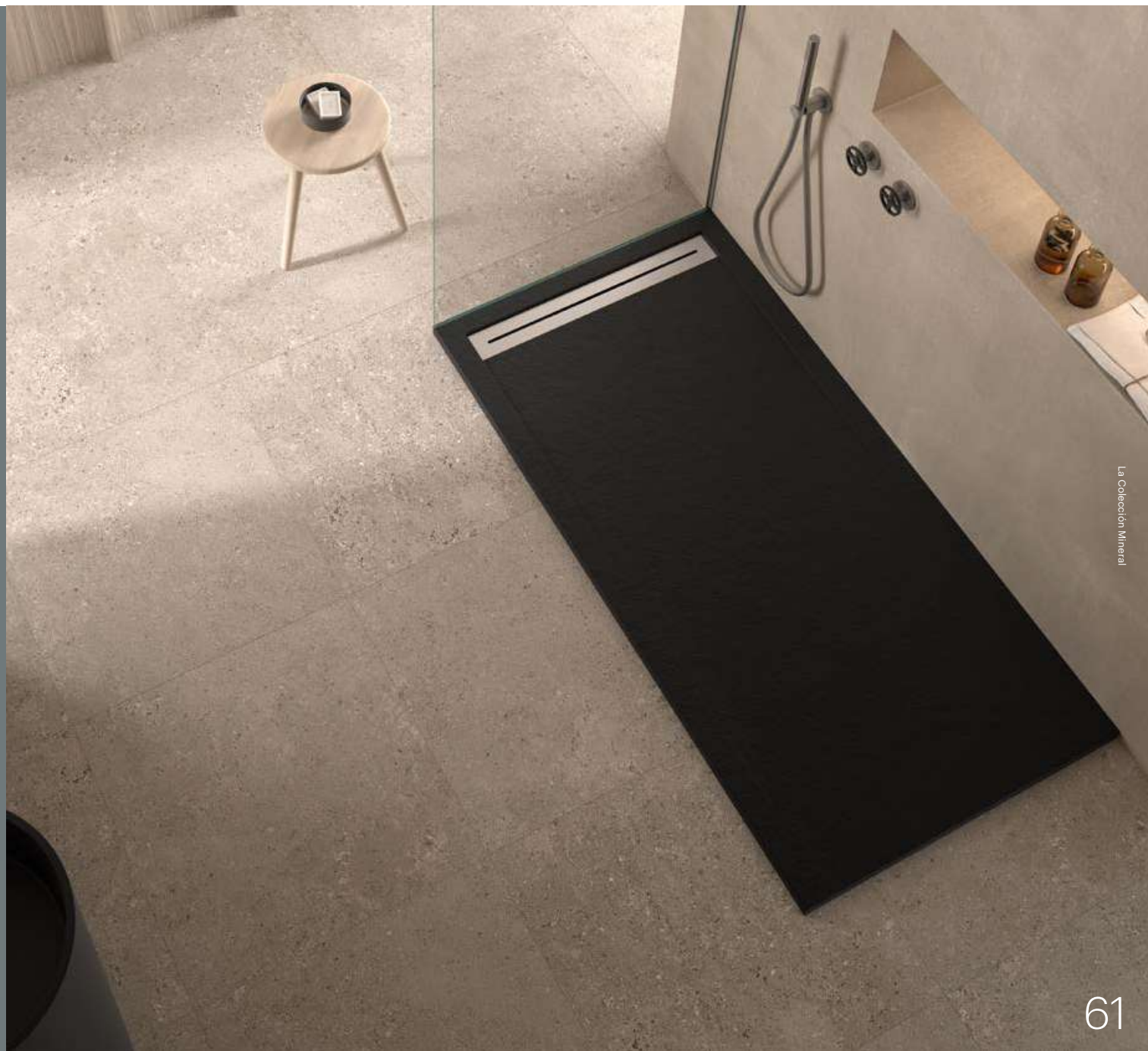



ⁱPizarra — ⁱArdoise — ⁱPizarra — ⁱSlate — ⁱPizarra

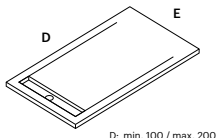

D: min. 100 / max. 200  
E: min. 80 / max. 100

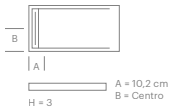

A = 10,2 cm  
B = Centro  
H = 3

Doccia Group

- 
- 
- 
- 
- 
- 
- 
- 
- 
- 
- 
- 
- 
- 
- 



Cuarzo Fuji, Kaki, Inox 4



Cuarzo Fuji, Talco, Blanco 4



La Colección Mineral

# ARDOISE

GAMME — TEXTURE



POSITION ÉCOULEMENT ET POIDS

Classic Nano

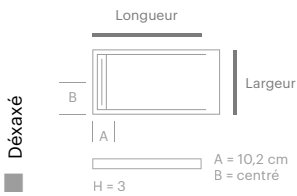

Longueur	Largeur		80	90	100
100	Cuarzo	■ 44 kg ■ 50 kg ■ 55 kg			
	Fuji	■ 27 kg ■ 31 kg ■ 34 kg			
120	Cuarzo	■ 53 kg ■ 59 kg ■ 66 kg			
	Fuji	■ 33 kg ■ 37 kg ■ 41 kg			
140	Cuarzo	■ 62 kg ■ 69 kg ■ 77 kg			
	Fuji	■ 38 kg ■ 43 kg ■ 48 kg			
160	Cuarzo	■ 70 kg ■ 79 kg ■ 88 kg			
	Fuji	■ 44 kg ■ 49 kg ■ 54 kg			
180	Cuarzo	■ 79 kg ■ 89 kg ■ 99 kg			
	Fuji	■ 49 kg ■ 55 kg ■ 61 kg			
200	Cuarzo	■ 88 kg ■ 99 kg ■ 110 kg			
	Fuji	■ 54 kg ■ 61 kg ■ 68 kg			

COULEURS STANDARD ET TENDENCIA

COULEURS ST

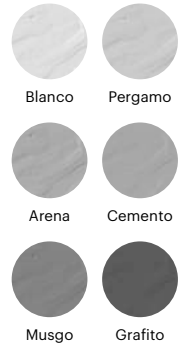

COULEURS TENDENCIA



CARACTÉRISTIQUES



Classic Warranty



DIN C4/Classe 3 PN24



Nano Warranty



3 cm épaisseur



Accès PMR

**SUPPLÉMENTS**

**DÉCOUPE**

**Découpe standard**  
(Découpe uniquement sur la longueur)

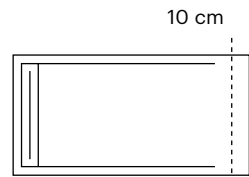

Inclus

**Découpe spéciale:**  
(Forfait à partir de la deuxième découpe et spéciale, au cm)

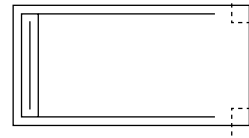

60 €

**COULEURS**

**Couleurs ST** Inclus  
**Couleurs Tendencia** + 50 €  
**RAL / NCS** + 103 €

**ZONE SÈCHE / BORDURE / HABILLAGE**

**Zone sèche:**  
(Texture Ardoise)  
Dim. 100 x 100 x 30

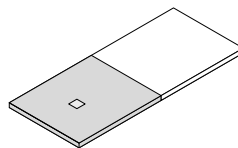

Couleurs ST 230 €  
Tendencia, Ral 250 €

**Habillage:**  
(Texture Lisse)  
Dim. 60-200X10X1,9

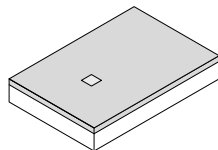

Couleurs ST 1,50 €  
Tendencia, Ral 1,80 €  
\* par cm linéaire

**OPTIONS**

**GRILLES**



**Grille laquée**  
6 couleurs ST  
Livrée en standard



675-775-875

Inclus



**Grille Caniveau  
Inox Brossé**  
Livrée en  
remplacement de  
la grille standard



675-775-875

Inclus

**BONDES**



**Bonde SH Doccia linéaire**  
Coloris blanc - 40 l/mn  
Livrée en Standard

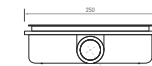

Inclus

A

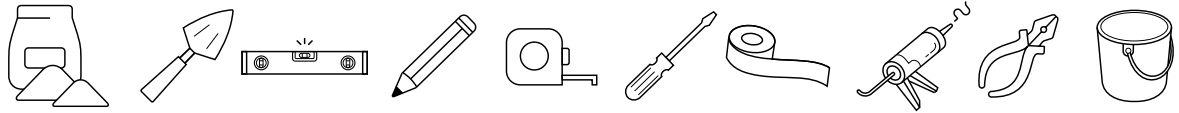

B

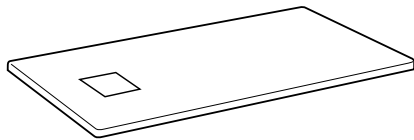
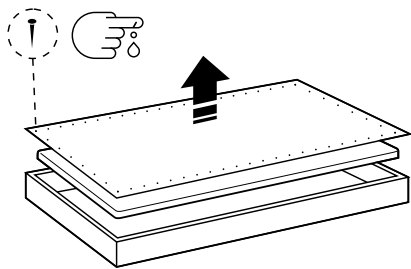
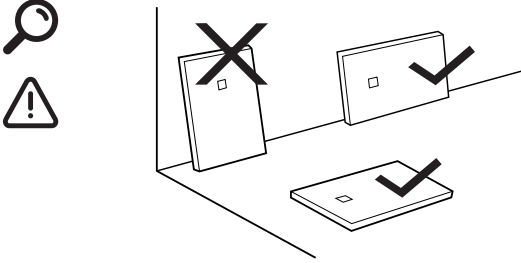

C

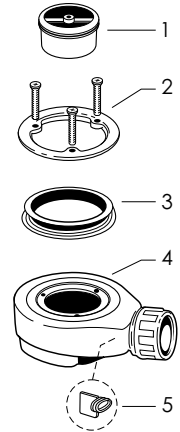
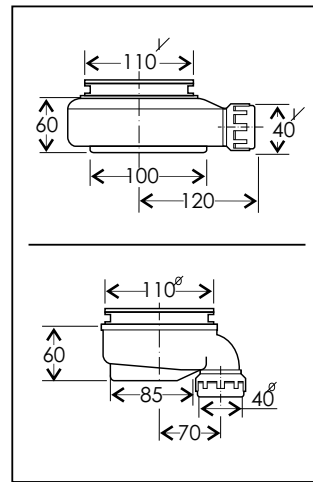
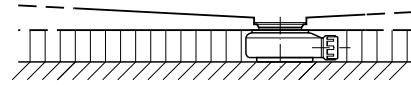
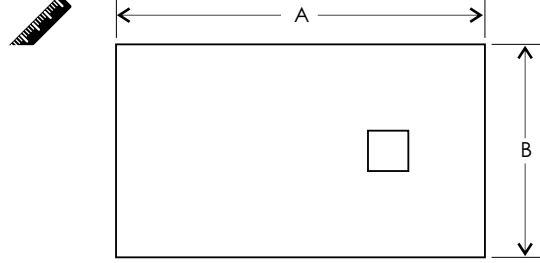

D

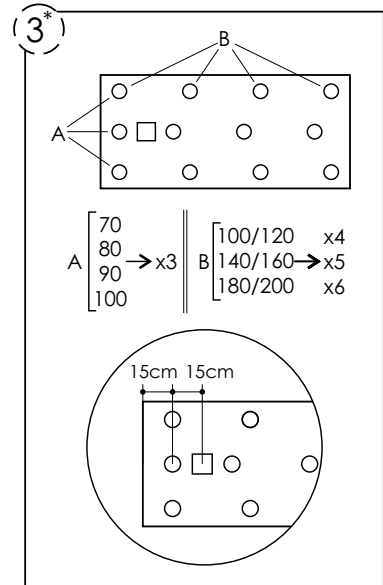
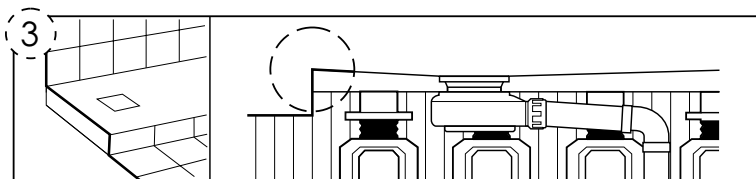
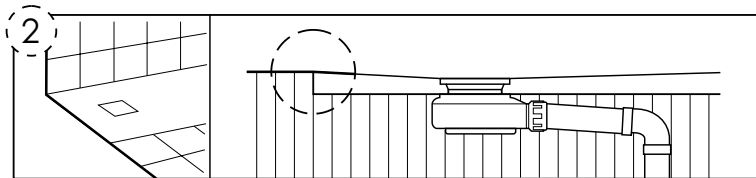
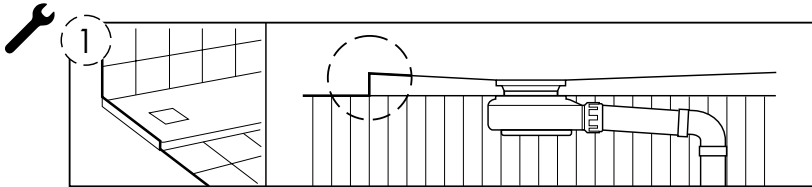



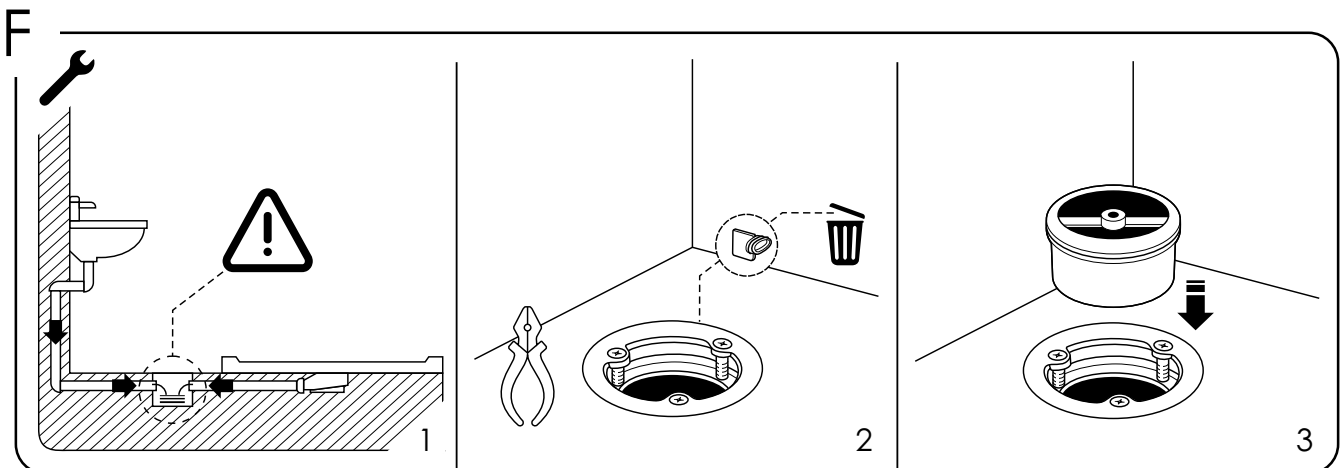
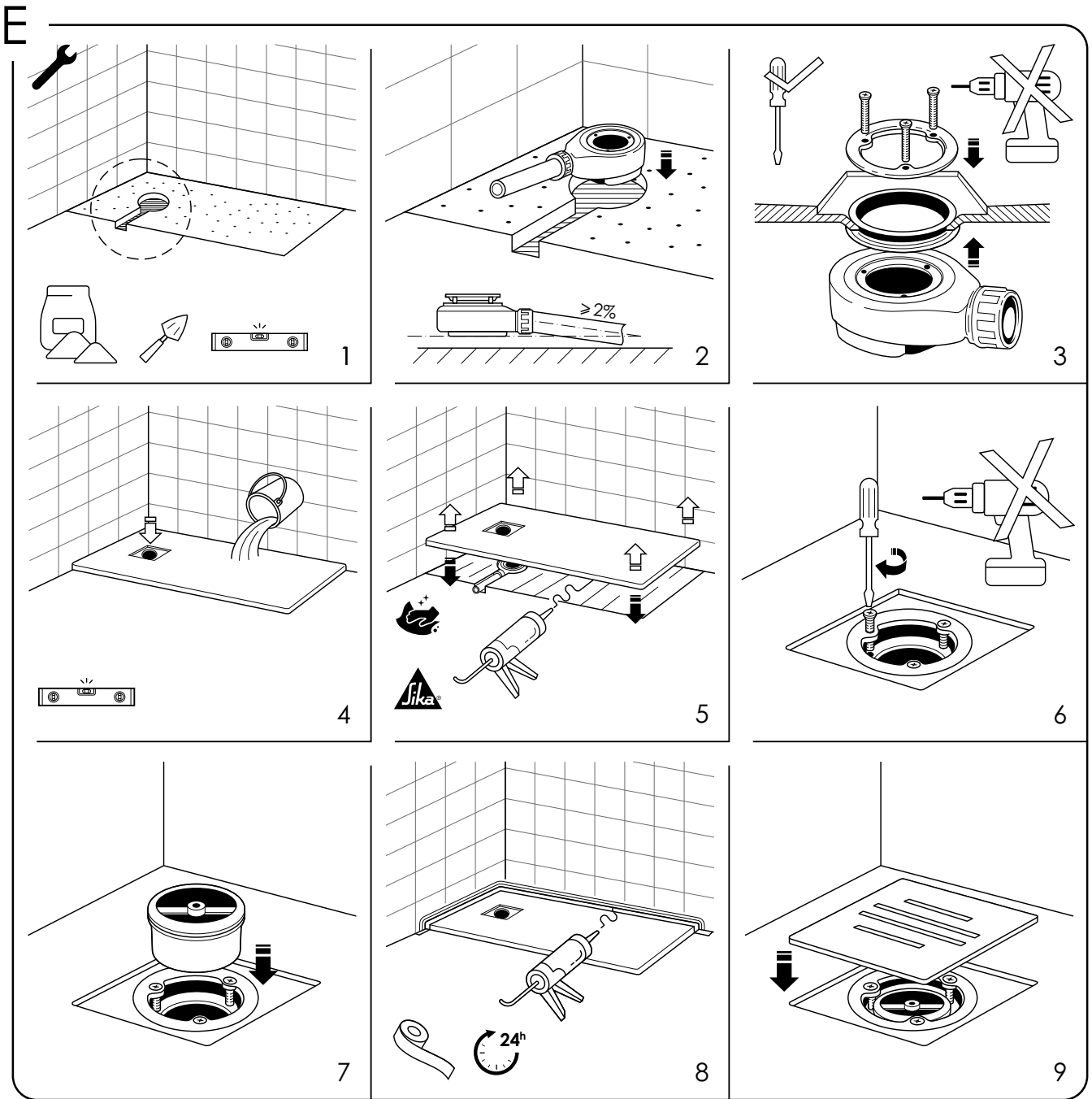

G

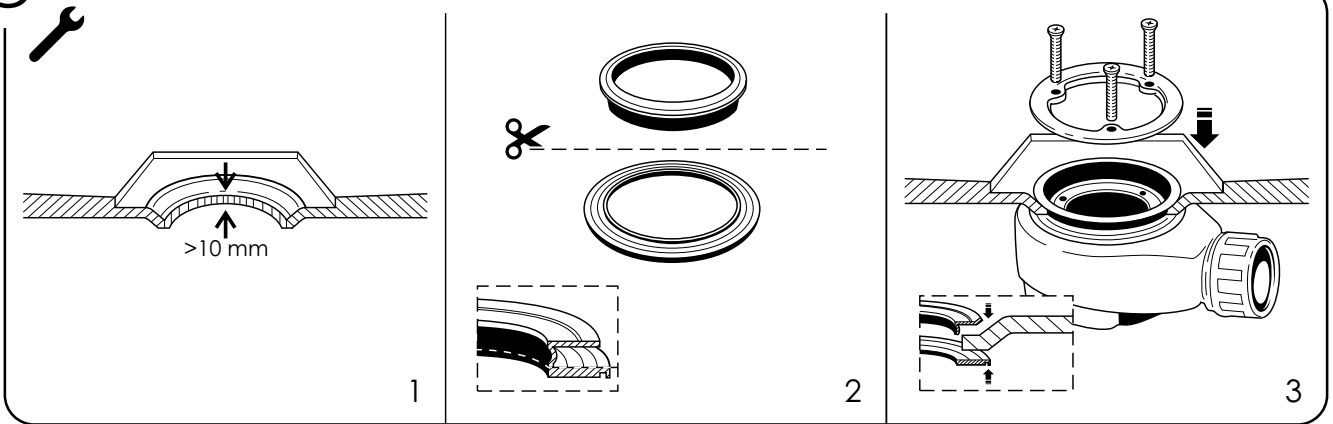

H

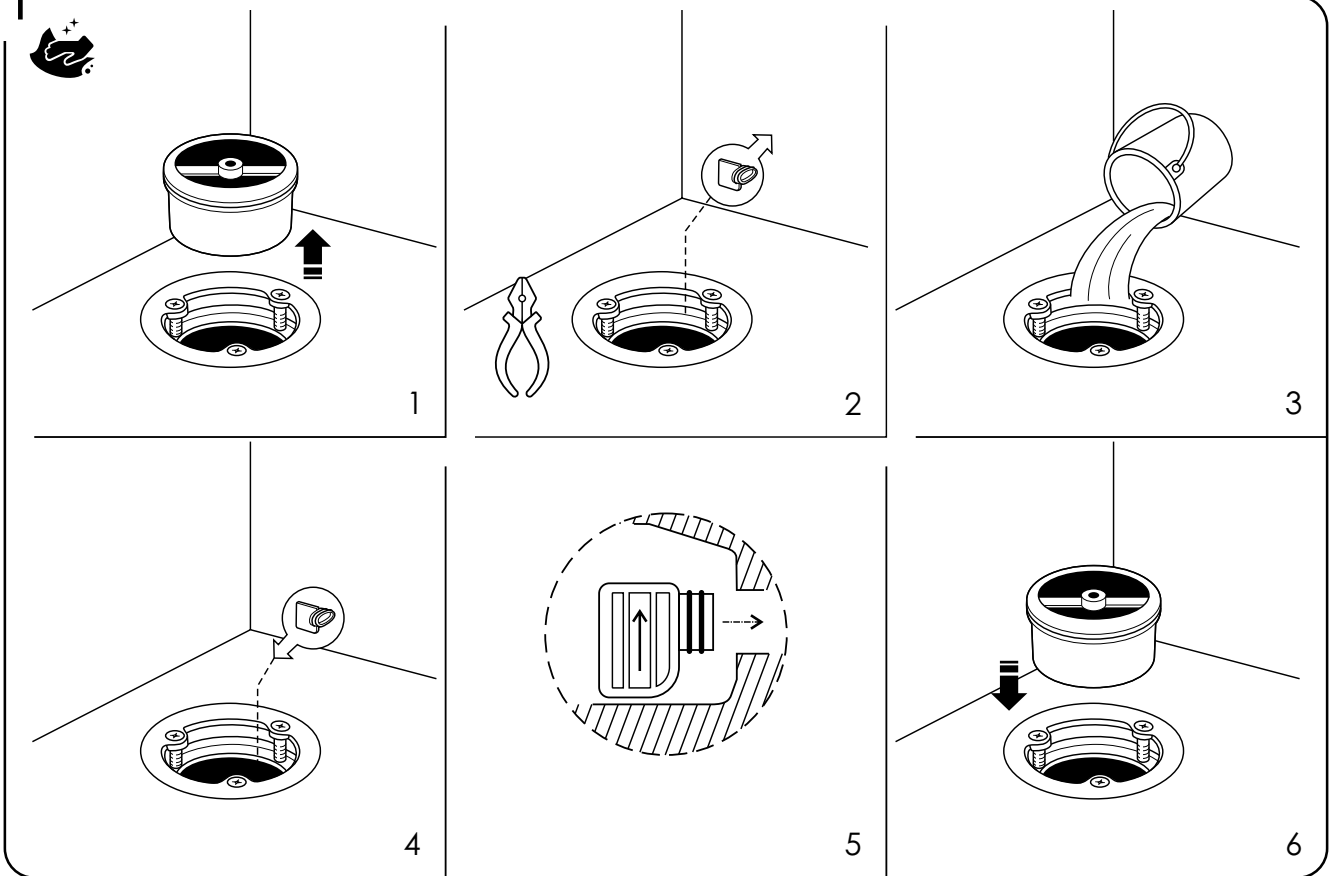

I

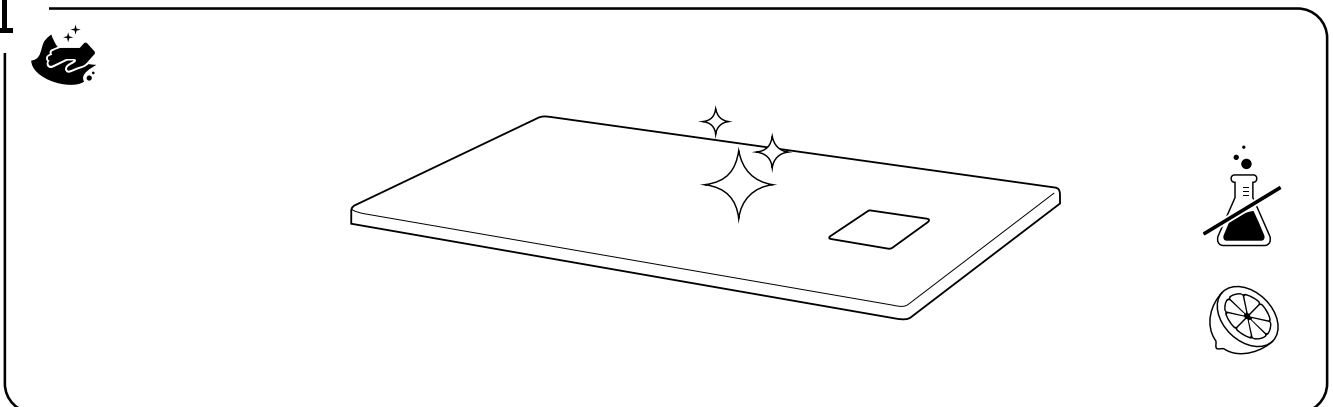

**A**

(ES) HERRAMIENTAS NECESARIAS	(FR) OUTILS NÉCESSAIRES	(EN) TOOLS NEEDED FOR ASSEMBLY	(IT) UTENSILI NECESSARI	(DE) NOTWENDIGE WERKZEUGE	(PT) FERRAMENTAS NECESSÁRIAS
------------------------------	-------------------------	--------------------------------	-------------------------	---------------------------	------------------------------

**B**

<p><b>(ES) ALMACENAJE Y VERIFICACIÓN</b>                      Antes de instalar el plato de ducha, por favor, comprobar que:                      - Desagua correctamente.                      - No existen anomalías o daños superficiales.                      - Modelo, medida, color y textura son correctos.                      No se aceptan reclamaciones sobre el producto una vez instalado.</p> <p><b>(IT) STOCAGGIO E VERIFICA</b>                      Prima dell'installazione del piatto, si prega di controllare:                      - La corretta evacuazione dell'acqua.                      - Che non esistano anomalie o danni superficiali.                      - Che il modello, dimensioni, colore e finitura siano corrispondenti al suo ordine                      Non saranno accettate contestazioni dopo l'installazione del prodotto.</p>	<p><b>(FR) STOCKAGE ET CONTRÔLE</b>                      Avant d'installer le receveur de douche, vérifiez impérativement:                      - Le bon écoulement de l'évacuation.                      - Qu'il n'y ait pas d'anomalies ou de dommages superficiels.                      - Que le modèle correspond à votre commande.                      Nous n'acceptons pas de réclamations sur un receveur installé.</p>	<p><b>(EN) STOCK AND CHECK</b>                      Before fitting the tray, please verify the following:                      - That it drains correctly.                      - That there are no visible damages on the surface.                      - That the model, color and finish of the tray are correct.                      No claims are accepted after the product has been installed.</p>	<p><b>(DE) LAGERUNG UND ÜBERPRÜFUNG</b>                      Bevor Sie die Duschwanne installieren, überprüfen Sie bitte Folgendes:                      - Es fließt richtig aus.                      - Es gibt keine Fehler oder oberflächliche Schäden.                      - Modell, Abmessungen, Farbe und Textur sind korrekt.                      Nach der Installation werden keine Ansprüche auf das Produkt akzeptiert.</p>	<p><b>(PT) ARMAZENAGEM E VERIFICAÇÃO</b>                      Antes de instalar a base de duche, por favor confirmar que:                      - Esgota correctamente.                      - Não existem anomalias ou danos superficiais.                      - Modelo, medida, cor e textura são correctos.                      Não se aceitam reclamações sobre o produto depois de instalado.</p>
--	--	--	---	---

**C**

<p><b>(ES) MEDIDAS. TIPO DE VÁLVULA</b>                      Desagüe Horizontal / Desagüe Vertical.  <b>COMPONENTES DE LA VÁLVULA</b>                      1.Tubo de inmersión 2.Anilla de sujeción 3.Junta bilabial 4.Sifón 5.Tapón.</p> <p><b>(IT) DIMENSIONI. TIPO DI VALVOLE DI SCARICO</b>                      Scarico orizzontale / Scarico verticale  <b>COMPONENTI DELLA VALVOLA</b>                      1.Tubo d'immersione 2.Anello metallico di serraggio 3.Giunto bilabiale 4.Sifone 5.Tappo.</p>	<p><b>(FR) DIMENSIONS. TYPE DE BONDE</b>                      Sortie Horizontale / Sortie Verticale.  <b>COMPOSANTS DE LA BONDE</b>                      1.Godet de nettoyage 2.Bride de fixation à vis 3.Joint double 4.Corps de bonde 5.Bouchon.</p> <p><b>(DE) ABMESSUNGEN / ABLAUFGARNITUR</b>                      Horizontaler Ablauf / Vertikaler Ablauf.  <b>VENTILKOMPONENTEN</b>                      1.Tauchrohr 2.Klemmring 3.Doppeldichtung 4.Siphon 5.Stöpsel.</p>	<p><b>(EN) MEASUREMENTS. TYPE OF TRAP</b>                      Horizontal / Vertical.  <b>DRAINAGE SYSTEM PARTS AND FITTINGS</b>                      1.Drain pipe 2.Metal adjustment ring 3.Rubber circular joint 4.Trap 5.Plug.</p> <p><b>(PT) MEDIDAS. TIPO DE VÁLVULA</b>                      Esgoto Horizontal / Esgoto Vertical.  <b>COMPONENTES DA VÁLVULA</b>                      1.Tubo de imersão 2.Anilha de sujeição 3.Junta bilabial 4.Sifão 5.Tampa.</p>
---	--	--

**D**

<p><b>(ES) OPCIONES DE INSTALACIÓN:</b> 1.Básica / 2.Encastrada / 3.Elevada * Esquema de colocación de los soportes de elevación regulable. (Soporte recomendado: Antideslizamiento y con tuerca de ajuste 88-172mm)</p> <p><b>(FR) TYPES D'INSTALLATIONS:</b> 1.Pose sur chape / 2.Pose encastrée / 3.Pose sur plots * Schéma de positionnement des plots. (Support recommandé : Antidérapant et avec ajustement 88-172 mm)</p> <p><b>(EN) INSTALLATION OPTIONS:</b> 1.Standard / 2.Wetroom – like / 3.Raised * Instructions on how to install the tray raising it with a raiser kit. Doccia does not supply the raiser kit.</p> <p><b>(IT) OPZIONI D'INSTALLAZIONE:</b> 1.Basica / 2.Filo / 3.Con basamento * Schema d'installazione supporto elevazione regolabile (Supporto consigliato: antiscivolo e fornito con dado di regolazione 88-172mm)</p> <p><b>(DE) EINBAUMÖGLICHKEITEN:</b> 1.Aufgesetzt / 2.Eingebaut / 3.Gehoben * Installationsanleitung der verstellbarer Stützen. (Empfohlene Stützen: Anti-Rutsch und mit Einstellmutter 88-172 mm)</p> <p><b>(PT) OPÇÕES DE INSTALAÇÃO:</b> 1.Básica / 2.Escastada / 3.Elevada * Esquema de colocação dos suportes de elevação regulável. (Suporte recomendado: antiderrapante e com porca de ajuste 88-172mm)</p>
--

**E**

<p><b>(ES) INSTALACIÓN DEL PLATO DE DUCHA/VÁLVULA:</b> Recomendación Inicial: Si el plato de ducha a instalar mide más de 160 cm. se recomienda elevar varios milímetros la parte trasera para aumentar la pendiente de desagüe.</p> <ol style="list-style-type: none"> <li>Preparar la base de apoyo para el plato de ducha con el hueco para la válvula de desagüe. Alisar y nivelar.</li> <li>Colocar la válvula en la base conectándola al desagüe mediante un tubo de PVC. Comprobar que no sobresale por encima de la base. La pendiente del tubo debe ser al menos del 2%.</li> <li>Insertar la junta de goma bordeando el interior del desagüe del plato de ducha. Colocar el plato sobre la base de apoyo haciéndolo coincidir con el centro de la válvula. Montar la anilla de sujeción apretando los tornillos uniformemente. No utilizar atornillador eléctrico.</li> <li>Comprobar que el plato desagua correctamente y está nivelado.</li> <li>Desmontar la válvula de desagüe. Retirar el plato de ducha y limpiar la base de apoyo. Aplicar el adhesivo recomendado ( Sikaflex o similares ) y fijar el plato de ducha a la base comprobando que esté nivelado.</li> <li>Volver a montar la válvula de desagüe. No utilizar atornillador eléctrico.</li> <li>Insertar el tubo de inmersión en la válvula.</li> <li>Proteger la superficie del plato con cinta de enmascarar. Proceder al sellado de las juntas mediante silicona, masilla o similares. Esperar un mínimo de 24h. para asegurar su correcto secado.</li> <li>Colocar la rejilla embellecedora. El plato de ducha está listo para su uso.</li> </ol>
--

#### **(FR) PLACEMENT DU RECEVEUR**

Recommandation initiale: Si le receveur à installer mesure plus de 160 cm. Nous conseillons d'élever plusieurs millimètres la partie arrière du receveur afin de faciliter l'écoulement.

1. À l'emplacement de la douche, tracer au sol les dimensions en laissant 1 cm de marge aux pourtours. Prévoir le décaissement de la bonde. La surface de pose ou chape devra être lisse et à niveau.
2. Placer précisément le siphon et le raccordement à l'évacuation des eaux. Celle-ci devra avoir une pente de 2% pour une évacuation optimale.
3. Placer le joint double dans l'orifice d'évacuation. Placer le receveur sans le coller afin de vérifier que l'emplacement de la bonde correspond à l'orifice d'évacuation. Fixer la bride de fixation en prenant la précaution de ne pas serrer manuellement et de manière uniforme. Ne pas visser à la visseuse électrique.
4. Vérifier que l'évacuation est optimale et que le receveur n'a aucun défaut de pente.
5. démonter la bonde, retirer le receveur, dépoussiérer la chape et appliquer la colle recommandée (Sikaflex ou similaire)
6. Fixer le receveur sur la chape en contrôlant les niveaux souhaités.
7. Monter la bride de fixation en vissant progressivement les vis de manière manuelle. Sans forcer ni utiliser de visseuse. Mettre en place le godet de nettoyage.
8. Protéger le receveur pendant l'installation. Mettre en place les joints d'étanchéité ou siliconer. Attendre minimum 24h pour un séchage complet.
9. Enlever les protections et mettre en place la grille de vidage. Le receveur est prêt à l'usage.

#### **(EN) ASSEMBLY INSTRUCTIONS**

Initial suggestion: For trays larger than 1600 it is suggested to raise a few mm. the side opposite to the location of the waste to give the tray a better slope.

1. Set the position of the valve and prepare a flat base.
2. Install the valve and make sure it is leveled with the base. Connect it to the waste pipe. Then make sure the slope of this drainage system is at least 2%.
3. Place the circular rubber joint in the waste location of the tray. Once you have made sure that the waste location of the tray and the valve are correct you can clean and prepare the base where the tray will sit. Fit the metal adjustment ring and screw it to the valve. Try not to use power drill.
4. Check that the tray drains properly and it is leveled correctly.
5. Now you can uninstal the tray and clean the flat base. Apply the proper adhesive product on that flat base (Sikaflex or similar) and now you can place the tray again on the base and make sure it is leveled.
6. Install the drain valve again. Try not to use a power drill.
7. Connect trap and waste pipe.
8. Proceed to sealing. Cover and protect the surface of the tray while sealing. Wait a minimum of 24 hours to make sure it dries correctly.
9. Place the grate in its location. The shower tray is now ready to use!!

#### **(IT) INSTALLAZIONE DEL PIATTO / VALVOLA**

Raccomandazione iniziale: Nel caso che la lunghezza del piatto sia superiore a 160 cm si consiglia di sollevare di alcuni millimetri la parte posteriore per aumentare la pendenza dello scarico.

1. Preparare la base di supporto per il piatto doccia con il foro per la valvola di scarico. Spianare e livellare.
2. Posizionare la valvola nella base connettendola allo scarico mediante un tubo in PVC. Controllare che il tubo sia in una posizione inferiore alla base. Si consiglia una pendenza del tubo di almeno 2%.
3. Inserire il giunto di gomma intorno al bordo del foro di scarico del piatto doccia. Alloggiare il piatto sopra la base di appoggio facendolo coincidere con il centro della valvola. ISTALLARE l'anello metallico di serraggio avvitandolo uniformemente. Non usare cacciaviti elettrici.
4. Controllare che il piatto sia a livello e scarichi correttamente.
5. Smontare la valvola di scarico. Togliere il piatto doccia e pulire la base di supporto. Fissare il piatto con il collante raccomandato (Sikaflex o simile) alla base di appoggio e controllare che sia a livello.
6. Montare la valvola di scarico di nuovo. Non usare cacciaviti elettrici.
7. Inserire il tubo di sostegno della griglia di sicurezza nella valvola di scarico.
8. Proteggere la superficie del piatto con nastro adesivo. Timbrare le giunte delle pareti con silicone, stucco o similari. Aspettare almeno 24 ore per un asciugato corretto.
9. Sistemare la griglia decorativa. Il piatto doccia è pronto per l'uso.

#### **(DE) EINBAU DER DUSCHWANNE / ABLAUFGARNITUR**

Empfehlung: Wenn die zu installierende Duschwanne grösser als 160 cm ist, es wird empfohlen, den hinteren Teil mehrere Millimeter anzuheben, um die Neigung des Abflusses zu erhöhen.

1. Bereiten Sie die Standfläche für die Duschwanne mit der Aussparung für das Ablaufgarnitur vor. Es must Glatt und eben sein.
2. Setzen Sie der Siphon, indem Sie es mit einem PVC-Rohr an den Abfluss anschließen. Stellen Sie sicher, dass es nicht über denr Boden hinausragt. Die Neigung der Röhre muss mindestens 2% betragen.
3. Setzen Sie die Gummidichtung entlang der Innenseite des Duschwannenabflusses ein. Legen Sie die Duschplatte auf die vorgesehene Fläche passend zur Mitte des Ventils. Montieren Sie den Klemmring, indem Sie die Schrauben gleichmäßig anziehen. Verwenden Sie keinen elektrischen Schraubendreher.
4. Kontrollieren Sie, ob die Duschwanne richtig abläuft und eben ist.
5. Entfernen Sie das Ablaufventil. Entfernen Sie die Duschwanne und reinigen Sie gründlich die Standfläche. Tragen Sie den empfohlenen Kleber (Sikaflex o.ä.) auf und fixieren Sie die Duschwanne an die Fläche und prüfen Sie, ob sie eben ist.
6. Das Ablaufventil wieder zusammenbauen. Verwenden Sie keinen elektrischen Schraubendreher.
7. Stecken Sie das Tauchrohr in das Ventil.
8. Schützen Sie die Oberfläche der Platte mit Malerband. Fahren Sie fort, um die Verbindungen mit Silikon oder ähnlichem zu versiegeln. Lassen Sie es mindestens 24 Stunden trocknen.
9. Positionieren Sie das Ziergitter. Die Duschwanne ist gebrauchsfertig.

#### **(PT) INSTALAÇÃO DA BASE DE DUCHE/VÁLVULA**

**Recomendação inicial:** Se a base de duche a instalar mede mais de 160cm recomenda-se elevar varios milímetros a parte traseira para aumentar a pendente de esgoto.

1. Preparar a base de apoio para a base de duche com a abertura para a válvula de esgoto. Alisar e nivelar.
2. Montar a válvula na base de apoio ligando-a ao esgoto mediante um tubo de PVC. Comprovar que não sobressai por cima da base de duche. A pendente do tubo deve ter no mínimo 2%.
3. Introduzir a junta de borracha no rebordo da abertura da base de duche. Colocar a base de duche sobre a base de apoio fazendo-a coincidir com o centro da válvula. Montar a anilha de sujeição apertando os parafusos uniformemente. Não utilizar aparafusadora eléctrica.
4. Confirmar que a base de duche esgota correctamente e está nivelada.
5. Desmontar a válvula de esgoto. Retirar a base de duche e limpar a base de apoio. Aplicar o produto aderente recomendado (Sikaflex ou similares) e fixar a base de ducha à base de apoio confirmando que está nivelada.
6. Voltar a montar a válvula de esgoto. Não utilizar aparafusadora eléctrica.
7. Introduzir o tubo de imersão na válvula.
8. Proteger a superfície da base de duche com fita de protecção. Proceder à selagem das juntas mediante silicone, massa ou produtos similares. Esperar no mínimo 24 horas para assegurar uma secagem correcta.
9. Colocar a tampa embelezadora. A base de duche está pronta para ser utilizada.

**F**  
**(ES) CASO ESPECIAL 1:** Sanitario con bote sifónico ya instalado. **(FR) CAS PARTICULIER 1:** Un siphon existe déjà dans l'installation.  
**(EN) ESPECIAL CASE 1:** Installation when the trap is already installed. **(IT) CASO SPECIFICO 1:** Sifone già esistente nella installazione.  
**(DE) SONDERFALL 1:** Badezimmer mit bereits installiertem Siphondose. **(PT) CASO ESPECIAL 1:** A casa de banho já tem um sifão.

**G**  
**(ES) CASO ESPECIAL 2:** Grosor del desagüe > 10 mm. **(FR) CAS PARTICULIER 2:** L'épaisseur du siphon est > 10 mm.  
**(EN) ESPECIAL CASE 2:** Thikness of the drain system > 10mm. **(IT) CASO SPECIFICO 2:** Spessore dello scarico > 10 mm.  
**(DE) SONDERFALL 2:** Größe der Ablaufrohr > 10 mm. **(PT) CASO ESPECIAL 2:** A espessura do esgoto > 10mm.

**H**  
**(ES) LIMPIEZA DEL SISTEMA DE DESAGÜE** **(FR) NETTOYAGE DU SYSTÈME D'ÉVACUATION** **(EN) CLEANING OF THE TRAP**  
**(IT) PULIZIA DEL SISTEMA DI SCARICO** **(DE) REINIGUNG DES ABLAUFGARNTUR** **(PT) LIMPEZA DO SISTEMA DE ESGOTO**

**I**  
**(ES) LIMPIEZA Y MANTENIMIENTO DEL PLATO DE DUCHA**  
La limpieza debe realizarse con cuidado de no dañar la superficie. Utilizar un paño suave o esponja húmeda no abrasiva con jabón neutro y agua tibia. Aclarar y secar. No utilizar productos de limpieza o desinfectantes agresivos (disolventes, ácidos, decapantes, lejías, alcoholes...) Solo en el caso de que se requiera de una limpieza más profunda (sobre todo si el plato es de color oscuro) es posible utilizar vinagre de manzana aplicado sobre un paño suave y de color oscuro.

#### **(FR) NETTOYAGE ET ENTRETIEN DU RECEVEUR DE DOUCHE**

Le nettoyage du receveur de douche doit se réaliser avec soin pour ne pas endommager la surface. Utiliser un torchon ou une éponge humide non abrasive avec du savon neutre et de l'eau tiède. Rincer et sécher. Proscrire les produits de nettoyage avec Ph élevé, alcalins, acides, détergent, solvants ou abrasifs (Eau de javel, eau forte, ammoniacque, décapants, dissolvants, alcool...) Dans le cas d'un nettoyage plus profond, par exemple laitance de chantier. Il est recommandé de nettoyer avec du dissolvant sur torchon blanc pour les receveurs blancs, et avec du vinaigre blanc sur torchon noir pour les couleurs sombres comme le noir ou graphite.

#### **(EN) CLEANING OF THE SHOWER TRAY**

The cleaning of the shower tray has to be done without damaging the surface of the tray.  
Use a soft cloth or a wet sponge with standard soap and warm water. Rinse and let dry.  
Don't use abrasive products or very aggressive cleaning products as well as strong solvents. These products should only be used if the tray needs a more technical solution. White vinegar can be used for cleaning the tray as well.

#### **(IT) PULIZIA E MANUTENZIONE DEL PIATTO DOCCIA**

La pulizia del piano lavabo deve essere eseguita facendo attenzione a non danneggiare la superficie. Usare una spugna morbida non abrasiva con sapone neutro ed acqua tiepida. Sciacquare ed asciugare. Non utilizzare prodotti per la pulizia o disinfettanti aggressivi (solventi, acidi, sverniciatori, candeggina, alcool, ecc) Soltanto in caso di necessità, per una pulizia più accurata (specialmente per piatti in colori scuri), si consiglia l'uso di aceto di mele applicato con un tovagliolo morbido scuro.

#### **(DE) REINIGUNG UND PFLEGE DER DUSCHWANNE**

Die Reinigung sollte vorsichtig erfolgen, um die Oberfläche nicht zu beschädigen. Verwenden Sie ein weiches Tuch oder einen feuchten nicht scheuernden Schwamm mit neutraler Seife und warmem Wasser. Gründlich spülen und trocknen. Verwenden Sie keine aggressive Reinigungsmittel oder Desinfektionsmittel (Terpentin, Säuren, Bleiche, Alkohole...) Nur wenn es eine tiefere Reinigung erforderlich ist (besonders wenn die Duschwanne dunkel ist), kann man Apfel-essig verwenden. Es soll mit einem weichen und dunkler Tuch aufgetragen.

#### **(PT) LIMPEZA E MANUTENÇÃO DA BASE DE DUCHE**

A limpeza da base de duche deve ser realizada com cuidado para não danificar a superfície.  
Utilizar um pano suave ou esponja húmeda não abrasiva, com sabão neutro e água tépida. Limpar e secar. Não utilizar produtos de limpeza ou desinfectantes agressivos (disolventes, ácidos, decapantes, lexívia, álcool...). Apenas nos casos em que se requer uma limpeza mais profunda (sobretudo se a base de duche fôr de cor escura) é possível utilizar vinagre de maçã aplicado sobre um pano suave e de cor escura.

