



Un diseño único que nos permite agrupar dos espacios de ducha en un único plato. Nuestro plato Bizona tiene carácter propio, unificando minimalismo y vanguardia.

A unique design that allows us to group two shower spaces into a single tray. Our Bizona tray has its own character, unifying minimalism and the avant-garde.

Un design unique qui nous permet de regrouper deux espaces de douche en un seul receveur de douche. Notre receveur de douche Bizona a son caractère propre, faisant rimer minimalisme avec avant-garde.

Un design unico che ci consente di accorpate due spazi doccia in un unico piatto. Il nostro piatto Bizona è dotato di grande carattere e coniuga minimalismo e avanguardia.



Antideslizante clase 3
Non-slip surface class 3
Antidérapant de classe 3
Antiscivolo di classe 3

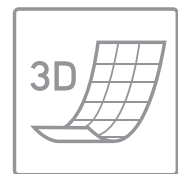

Curva de desagüe
Drainage curve
Pente d'écoulement
Curva di drenaggio

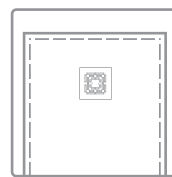

Planimetría mampara
Planimetry shower screen
Contour plat
Planimetria perimetrale

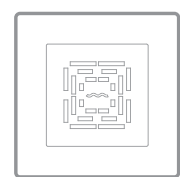

Rejilla inox. incluida
Stainless steel included
Grille acier Inox. inclus
Griglia in acciaio inox inclusa

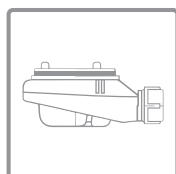

Válvula estandar incluida
Standard drainer included
Bonde standard inclus
Valvola standard inclusa

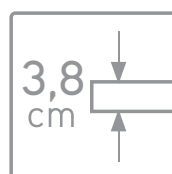

Espesor
Thickness
Épaisseur
Spessore

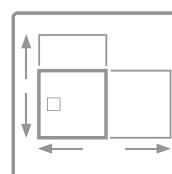

A medida
Made to measure
Sur mesure
Su misura

COMPLEMENTOS /
ACCESSORIES / ACCESSOIRES / ACCESSORI



HGM
Technology



Color RAL
RAL Colours
Couleurs RAL
Colore RAL

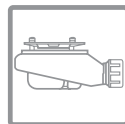

Válvula viega
Viega's drainer
Bonde viega
Valvola viega

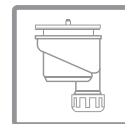

Válvula viega vertical
Viega's vertical drainer
Bonde viega verticale
Valvola viega verticale

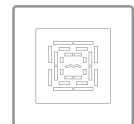

Rejilla de color
Color grid
Grille de couleurs
Griglia di colore

ACABADOS /
FINISHES / FINITION / FINITURA

10 colores ST-One | 9 texturas ST-One
10 colours ST-One | 9 textures ST-One
10 couleurs ST-One | 9 textures ST-One
10 colori ST-One | 9 tessiture ST-One

DIMENSIONES /
DIMENSIONS / DIMENSIONS / DIMENSIONI





Pergamón

Crema
RAL 9001

Mocca
RAL 1019

Musgo
RAL 7006

Gris Seda
RAL 7044

Cloud
RAL 7040

Gris Polvo
RAL 7037

Gris Cemento
RAL 7046

Antracita
RAL 7016

Negro

TEXTURES ST-ONE / TEXTURES ST-ONE

NEW

Soft - SO

Skin - SK

Mushroom - MU

Cuero - CU

A close-up view of a synthetic material with a fine, granular, and slightly irregular texture, resembling a fine-grained stone or concrete.

Sintetic - SI

A close-up view of a pizarra (slate) material with a smooth, slightly uneven surface and a subtle, natural-looking grain.

Pizarra - PI

A close-up view of a Gres-Tech material featuring a prominent, regular grid pattern of small, raised squares.

Gres-Tech - GT

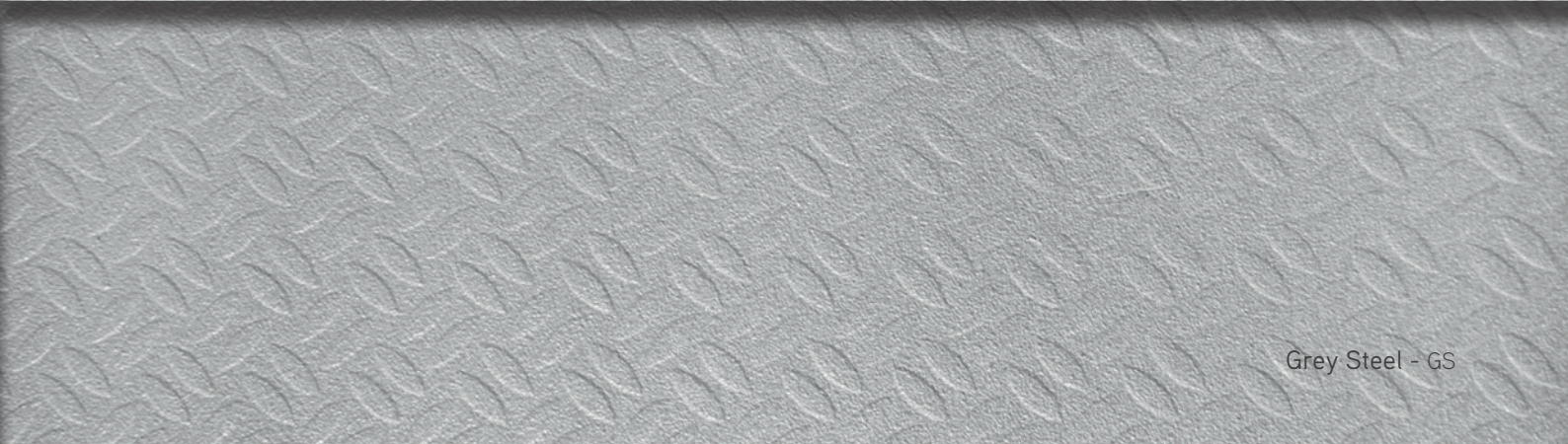
A close-up view of a Grey Steel material with a textured surface consisting of a repeating pattern of small, overlapping, teardrop-shaped motifs.

Grey Steel - GS

A close-up view of a Smooth Wood material with a fine, linear texture that mimics the grain of wood, showing subtle variations in tone and direction.

Smooth Wood - SW

ES Instrucciones de montaje

Antes de la instalación del plato de ducha, por favor, comprobar:

- Que el plato desagua correctamente.
- Que no existan anomalías o daños superficiales.

No se aceptarán reclamaciones de producto ya instalado, por lo que es importante revisar este previo a su instalación.

EN Installation guide

Please, before the installation of the shower tray be sure of:

- The shower tray has the drainage correctly.
- The surface of the shower tray is correct and there aren't defects on it.

Take into account that any claim will not be accepted of product that has been installed. Please, is important to check it out before the installation.

FR Consignes de montage

Avant l'installation du plateau de douche, vérifiez attentivement:

- Que la bonde du receveur de douche fonctionne correctement
- Qu'il n'y ait pas de défaut ou que le receveur ne soit pas abîmé

Aucune réclamation ne sera acceptée sur des produits déjà installés, c'est pourquoi il est important de réviser le produit avant son installation.

IT Istruzioni di montaggio

Prima di installare il piatto doccia, si prega di controllare:

- Che il piatto scarichi correttamente.
- Che non ci siano anomalie o danni superficiali.

Non si accettano reclami per prodotti già installati, per cui è importante verificarlo prima dell'installazione.

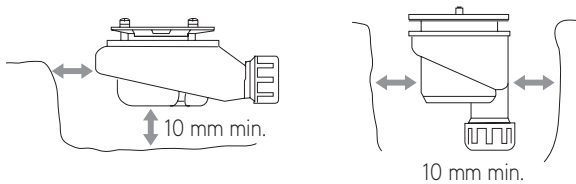

2

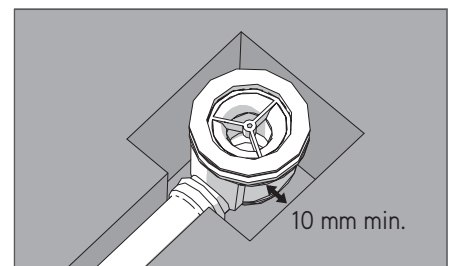
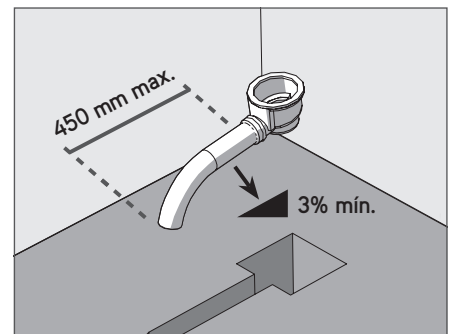
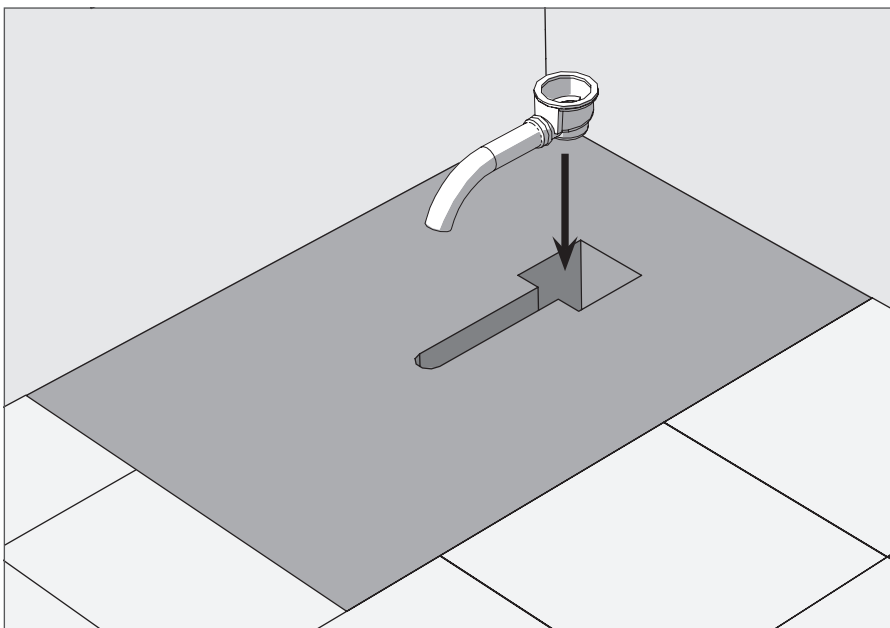

1

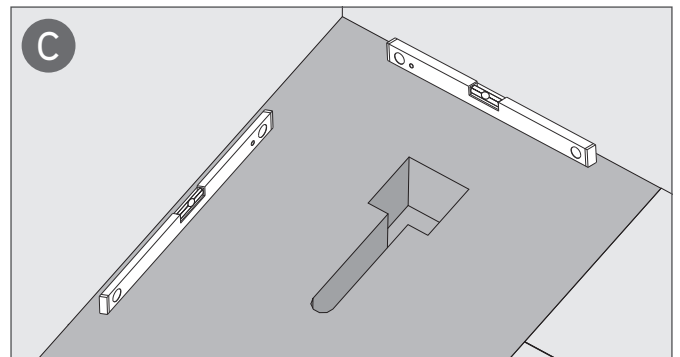
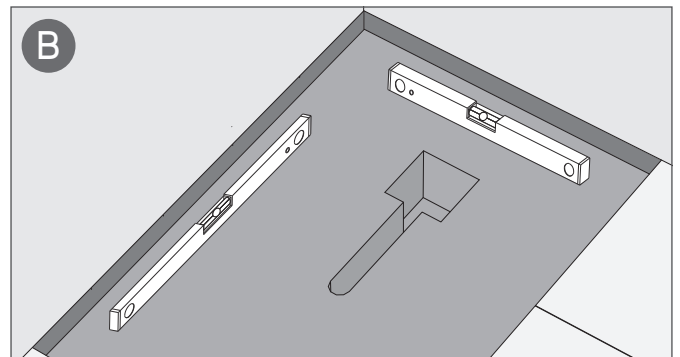
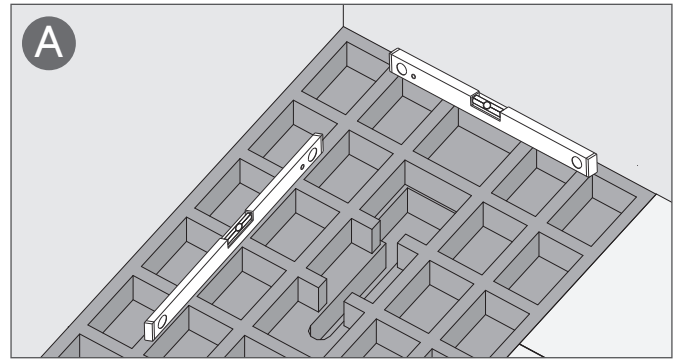

3

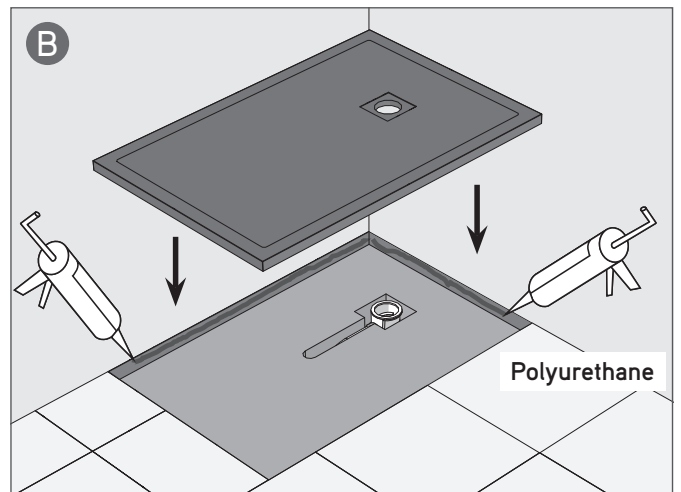
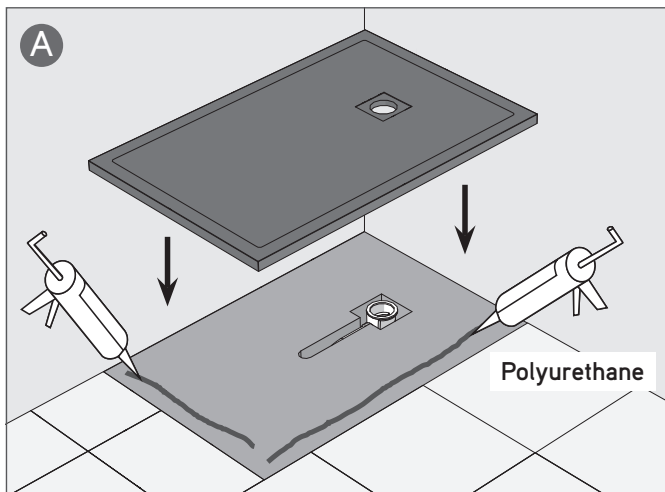

4

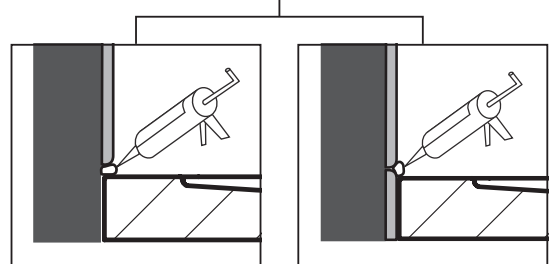
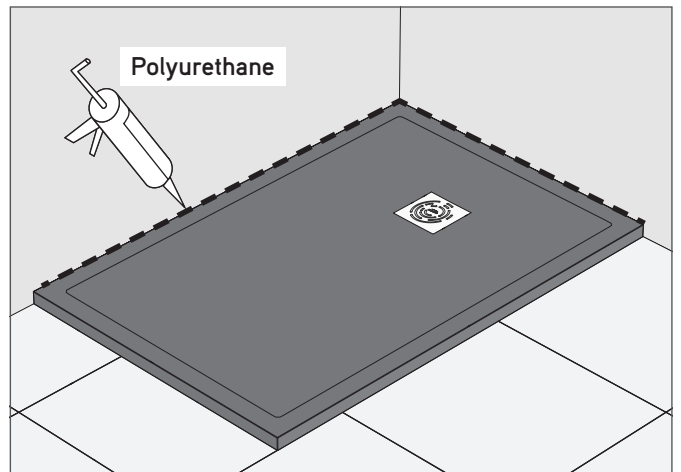
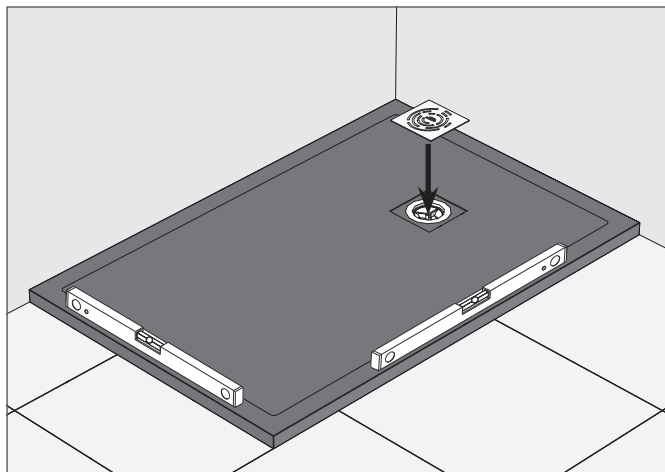

5

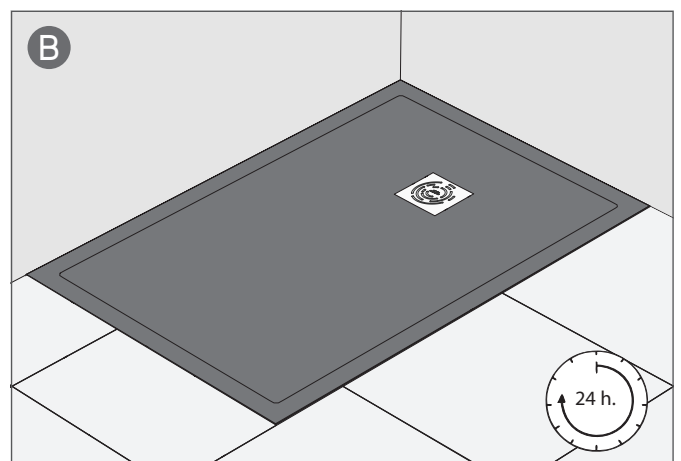
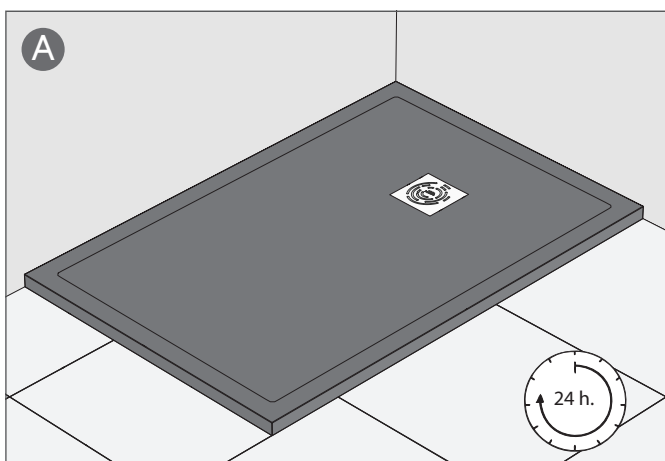

Casos especiales

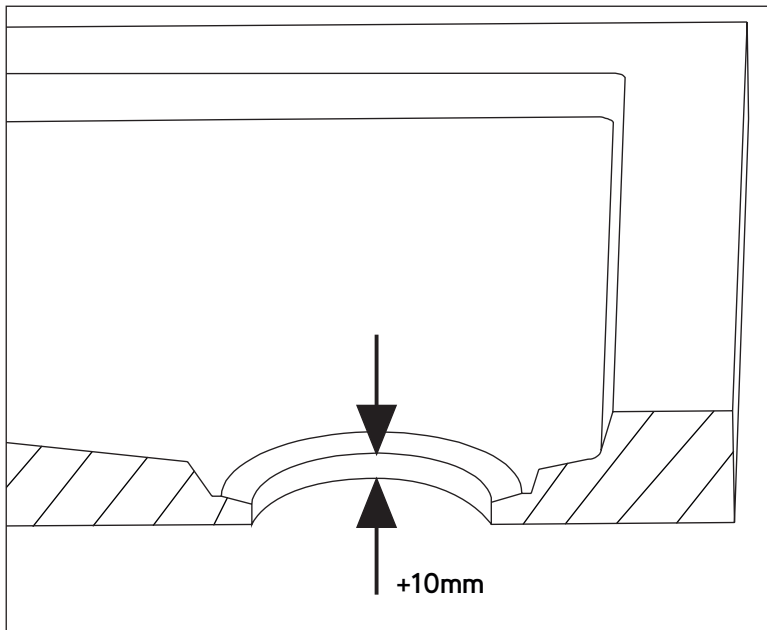

Si el grosor del plato supera las 10 mm hay que cortar la junta.

If the floor of the shower tray is thicker than 10mm, separate the seal.

Si l'épaisseur du fond du receveur de douche est + à 10mm, couper le joint.

Se il fondo del piatto doccia è spesso più di 10 mm, separare la guarnizione.

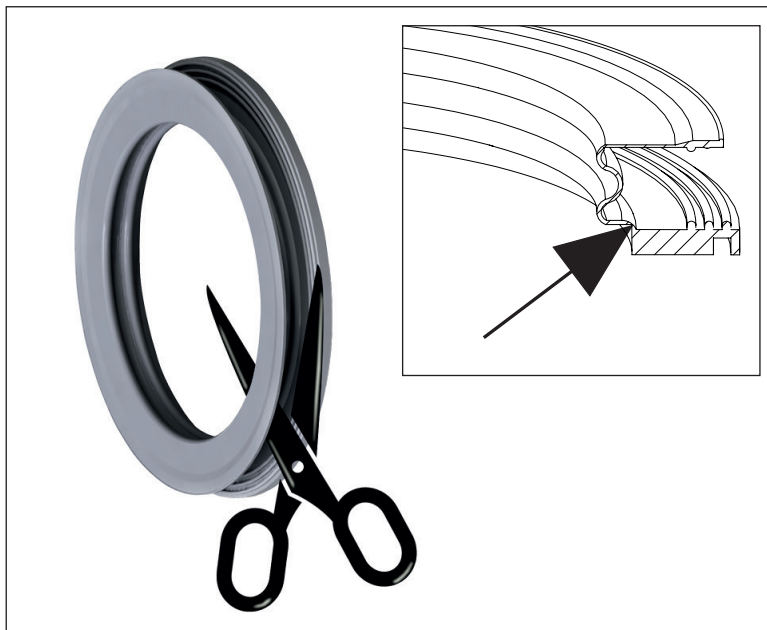

Cortar por encima del reborde inferior de la junta.

Cute above the lower sealing bead.

Couper au-dessus du bourrelet inférieur.

Tagliare al di sopra della guarnizione inferiore.

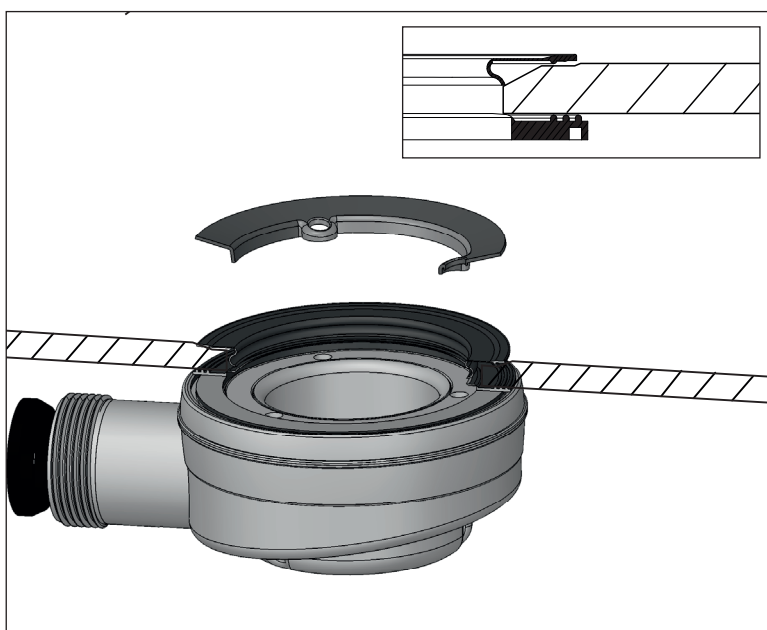

Colocar la parte inferior sobre el cuerpo de desagüe y la superior en el agujero de desagüe.

Place the lower part on the drain housing and the upper part in the drain hole.

Placer le haut sur à l'unité de base et le bas dans l'orifice.

Collocare la parte inferiore sulla scatola di scarico e la parte superiore nel foro di scarico.

UTILISATION ET D'ENTRETIEN / USO E MANUTENZIONE



Résistance aux produits d'entretien
Resistenza ai prodotti di pulizia di uso domestico

Produit / Prodotto	Exposition / Esposizione	Résultat / Risultato
Javel / Candeggina	24H	Résistant / Resiste
Acide Chlorhydrique / Acquaforte	24H	Résistant / Resiste
Monsieur propre / Mastro lindo	24H	Résistant / Resiste
Viakal	24H	Résistant / Resiste
Vinaigre / Aceto	24H	Résistant / Resiste
Ammoniaque / Ammoniacca	24H	Résistant / Resiste
KH-7	24H	Résistant / Resiste
Cillit Bang	1H	Résistant / Resiste
Vernis à ongles foncé / Smalto per unghie scuro	24H	Résistant / Resiste
Vernis à ongles clair / Smalto per unghie chiara	24H	Résistant / Resiste
Eau oxigénée / Acqua ossigenata	24H	Résistant / Resiste
Bétadine / Betadine	24H	Résistant / Resiste
Vin / Vino	24H	Résistant / Resiste

* Attention aux colorations pour cheveux (résiste à une exposition d'entre 5 et 30 minutes selon si la coloration est claire ou foncée) et à l'acétone (la couleur ou la brillance peuvent être altérées après une minute d'exposition).

* Prestare particolare attenzione con le tinture per capelli (in base a se il colore è chiaro o scuro, resiste per un periodo di esposizione compreso tra 5 e 30 minuti) e l'acetone (può alterare moderatamente la lucentezza e/o il colore dopo 1 minuto di esposizione).



Antibactériennes
Antibatterico

Notre traitement antibactérien **inhibe la croissance des champignons et des bactéries**, un outil très efficace **contre les taches et les odeurs**. Nos produits sont conformes à la norme Z2801 de l'institut JIS (Japanese Industrial Standard) et répondent au «Test for antimicrobial activity and efficacy» de 2006.

*Il nostro trattamento antibatterico **inibisce la crescita di funghi e batteri**, uno strumento molto efficace **contro le macchie e i cattivi odori**. Secondo l'istituto JIS (Japanese Industrial Standard) e la normativa Z2801 relativa al "Test for antimicrobial activity and efficacy" del 2006, i nostri prodotti sono conformi alla norma in questione.*



Antidérapant classe 3
Sistema antiscivolo classe 3

Classé au niveau 3 de la norme UNE-EN 12633:2003 qui détermine la valeur de l'antidérapement du produit.

Secondo la norma UNE-EN 12633:2003 che ci consente di determinare il valore della resistenza allo slittamento/scivolamento, il prodotto è conforme e rientra nella classe 3.