

ES	MANUAL DE INSTALACIÓN · Platos de ducha
EN	INSTALLATION MANUAL · Shower trays
FR	MODE D'INSTALLATION ET ENTRETIEN · Receveurs de douche
DE	INSTALLATION · Duschabtrennungen
IT	MANUALE D'USO E INSTALLAZIONE · Piatti doccia

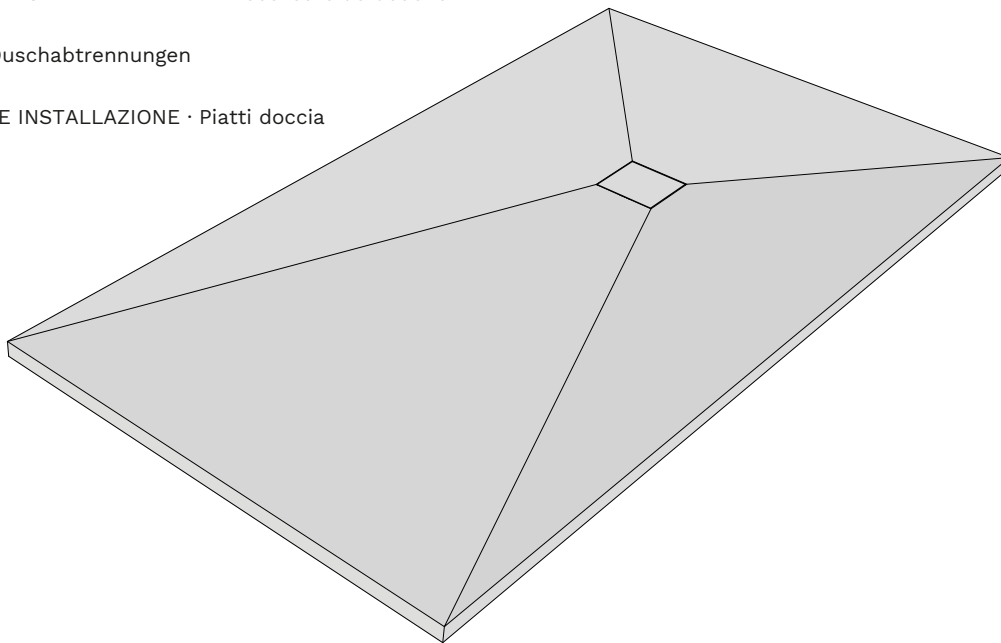

- ES ·Al recibir el producto verifique que corresponde con su pedido y que no haya sufrido ningún tipo de desperfecto, arañazo, golpe, etc. y se encuentra en perfecto estado para su instalación.
- EN ·Please check immediately that delivered shower tray is in conformity with your order, doesn't have any imperfection, scratch, impact, etc. and is in perfect conditions for installation.
- FR ·Veuillez vérifier à la livraison que le receveur correspond bien à votre commande, qu'il ne présente aucun défaut, rayure, choc, etc. et est en parfait état pour procéder à l'installation.
- DE ·Bitte prüfen sie sofort die gelieferte brausetasse, ob diese Ihrer bestellung entspricht, sie keinerlei sc häden wie abschürfungen, risse, cut's oder sonstige beschädigungen aufweist und diese sich in einem ordnungsgemäßen zustand für einen einbau befindet.
- IT · Si prega di verificare nella consegna che il prodotto corrisponde al suo ordine, che non abbiano imperfezioni, graffi, colpi, ecc. e che il prodotto è in perfette condizione per la sua installazione.

SOFT



PLATO DE DUCHA
SHOWER TRAY
RECEVEUR DE DOUCHE
PIATTO DOCCIA
DUSCHWANNE

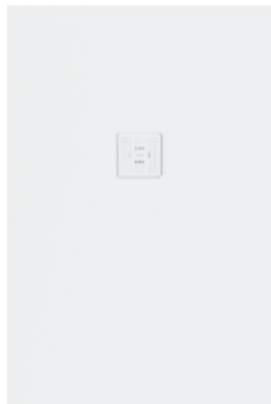

© SOLID



Glaciar White

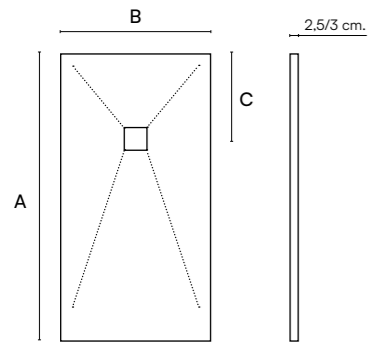

		A													
		80	90	100	110	120	130	140	150	160	170	180	190	200	210
B	70	41	41	41	41	41	41	41	41	61	61	61	61	61	61
	80	41	41	41	41	41	41	41	41	61	61	61	61	61	61
	90	-	41	41	41	41	41	41	41	61	61	61	61	61	61
	100	-	-	41	41	41	41	41	41	61	61	61	61	61	61
	110	-	-	-	41	41	41	41	41	-	-	-	-	-	-
120	-	-	-	-	41	41	-	-	-	-	-	-	-	-	

Para medidas superiores a esta tabla, consulten al departamento comercial.
 For measurements larger than those in this table, please consult the sales department.
 Pour mesures supérieures à ces tableaux, veuillez consulter le service commercial.
 Per misure più grandi di questa tabella, si prega di consultare il reparto vendite.
 Für größere, als in dieser Tabelle angegebenen Größen, wenden Sie sich bitte an die Verkaufsabteilung.

DOMO HORIZONTAL

- Válvula (estándar)
- Standard valve
- Bonde standard
- Valvola standard
- Ventil (standard)

- Rejilla inox / Blanco
- Inox / White color grid
- Grille couleur inox / Blanche
- Griglia inox a colore / Bianca
- Ablaufgitter Inox / Weiss

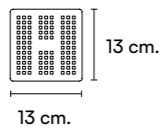

Caudal • Flow • Flux • Flusso • Durchfluss
35 l./min.



Sección E-E

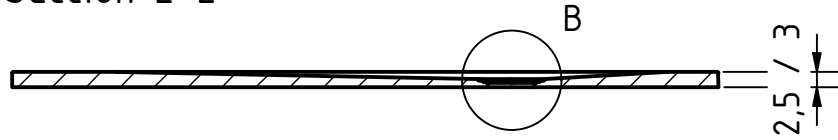

Detalle B

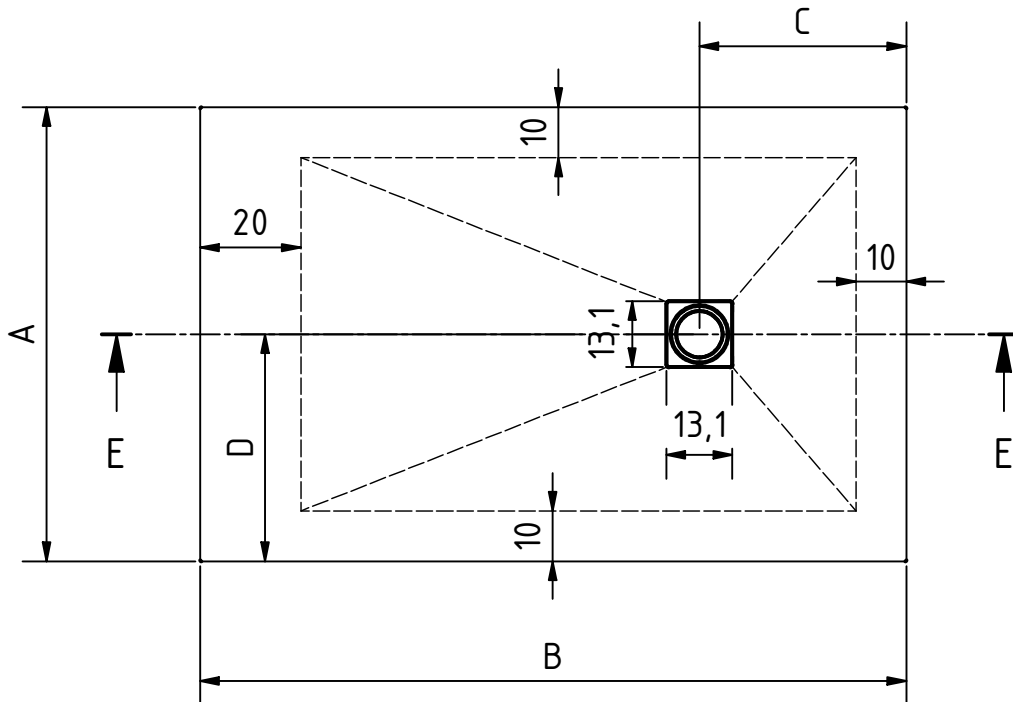
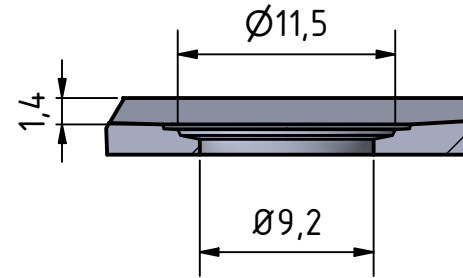

A	B	C	D
70	80 - 90 - 100 - 110 - 120 - 130 - 140 - 150 160 - 170 - 180 - 190 - 200 - 210	41 61	35
80	80 - 90 - 100 - 110 - 120 - 130 - 140 - 150 160 - 170 - 180 - 190 - 200 - 210	41 61	40
90	90 - 100 - 110 - 120 - 130 - 140 - 150 160 - 170 - 180 - 190 - 200 - 210	41 61	45
100	100 - 110 - 120 - 130 - 140 - 150 160 - 170 - 180 - 190 - 200 - 210	41 61	50
110	110 - 120 - 130 - 140 - 150	41	55
120	120 - 130	41	60

Anotaciones:

Fecha revisión

22/01/2024

Producto

Plato ducha
MAUI

Material

SOLID

cms

1/1

Dibujado por equipo
técnico Zenon

Opciones Platos de Ducha

Shower Tray Options • Option receveurs de douche • Opzione piatti doccia • Optionen duschwannen

GEL COAT ACABADO / TEXTURA GEL COAT TEXTURE / FINISH GEL COAT TEXTURE / FINITION GEL COAT CONSISTENZA / FINITURA GEL COAT AUSFÜHRUNGEN / TEXTUR



Soft Slate Korvit Stone

GEL COAT COLORES ESTÁNDAR GEL COAT STANDARD COLOURS GEL COAT COULEURS STANDARD GEL COAT COLORI STANDARD GEL COAT STANDARD FARBEN

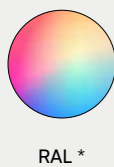

RAL *

* Disponible también en todos los colores de la carta RAL
* Also available in all colors of RAL chart
* Également disponible dans toutes les couleurs du nuancier RAL
* Disponibile anche in tutti i colori della carta RAL
* Auch verfügbar in allen Farben aus der RAL karte

SMART SOLID ACABADO / TEXTURA SMART SOLID TEXTURE / FINISH SMART SOLID TEXTURE / FINITION SMART SOLID CONSISTENZA / FINITURA SMART SOLID AUSFÜHRUNGEN / TEXTUR



Soft

SMART SOLID COLOR SMART SOLID COLOR SMART SOLID COULEUR SMART SOLID COLORE SMART SOLID FARBE

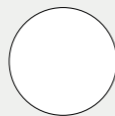

Classic White

SOLID ACABADO / TEXTURA SOLID TEXTURE / FINISH SOLID TEXTURE / FINITION SOLID CONSISTENZA / FINITURA SOLID AUSFÜHRUNGEN / TEXTUR

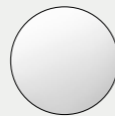

Soft

SOLID COLOR SOLID COLOR SOLID COULEUR SOLID COLORE SOLID FARBE

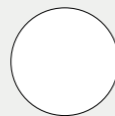

Glacier White

GEL COAT KIT DE REPARACIÓN GEL COAT REPAIR KIT GEL COAT KIT DE RÉPARATIONS GEL COAT KIT DI RIPARAZIONE GEL COAT REPARATIONSKIT

ES El trabajo de colocación de un nuevo baño puede ocasionar pequeños daños en los elementos con los que estamos trabajando, con frecuencia fruto de la rapidez de la instalación.

Zenon cuenta con varias opciones de reparación pensado especialmente en sus platos de ducha.

El kit consta de dos frascos, un rodillo de pintor para lacar, un recipiente y las instrucciones necesarias para realizar la reparación. También será necesaria una botella de alcohol, además de cinta de carrocer. Las instrucciones permitirán realizar la reparación de forma muy sencilla.

EN The installation work for a new bathroom can slightly damage the elements we are working with, often because of an installation that has been carried out too quickly.

Zenon has several repair options specially designed for its shower trays.

The Repair kit consists of two bottles, a paint roller for lacquering, a container and the necessary instructions for carrying out the repair. We will also need a bottle of alcohol and masking tape. The instructions will allow us to carry out the repair quite easily.

FR Le travail d'installation d'une nouvelle salle de bains peut provoquer des dégâts sur les éléments sur lesquels on travail. Cela est très souvent dû à la rapidité de l'installation.

Zenon propose plusieurs options de réparation spécialement conçues pour ses receveurs de douche.

Le kit de réparations comprend deux flacons, un rouleau de peintre pour laquer, un récipient et les instructions nécessaires pour réaliser la réparation. Une bouteille d'alcool et un ruban de masquage seront également nécessaires. Les instructions permettent d'effectuer la réparation en toute simplicité.

IT Il lavoro di installazione di un nuovo bagno può provocare piccoli danni agli elementi con cui si sta lavorando, frequentemente a causa della velocità.

Zenon mette a disposizione diverse opzioni di riparazione appositamente studiate per i suoi piatti doccia.

Il kit di riparazione consta di due boccette, un rullo per pittura, un recipiente e le istruzioni necessarie per eseguire la riparazione. Sarà inoltre necessaria una bottiglia dell'alcool denaturato di carrozziere. Le istruzioni permetteranno di eseguire la riparazione in modo semplicissimo.

DE Beim Einbau eines neuen Badezimmers kann es zu kleineren Schäden an den Elementen kommen, mit denen wir arbeiten, was oft auf die Geschwindigkeit der Installation zurückzuführen ist.

Zenon bietet, speziell für seine Duschwannen geeignete Reparaturoptionen an.

Das Set besteht aus zwei Flaschen, einem Farbroller, einem Behälter und der notwendigen Anleitung für die Reparatur. Sie benötigen außerdem eine Flasche Alkohol und Klebeband. Mit Hilfe der Anleitung ist die Reparatur sehr einfach durchzuführen.

Mini paint Kit
Mini Kit de pintura
Mini-Kit de peinture
Mini Kit di pittura
Mini-Bemalungsset



Repair kit
Kit de reparación
Kit de réparations
Kit di riparazione
Reparationskit



Multi-purpose one-component adhesive and sealer
Adhesivo y sellador multiuso monocomponente
Adhésif et scellant multi-usages mono-composant
Adesivo e sigillante multiuso monocomponente
Einkomponentiger Mehrzweckklebstoff und Dichtstoff

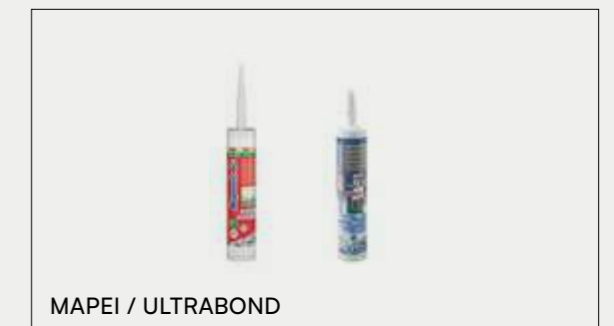

MAPEI / ULTRABOND

Opciones Platos de Ducha

Shower Tray Options • Option receveurs de douche • Opzione piatti doccia • Optionen duschwannen

VÁLVULA VALVE BONDE VALVOLA VENTIL

DOMO HORIZONTAL

Smart
Frame
Evolution
Angular
Maui
Bali
Capri

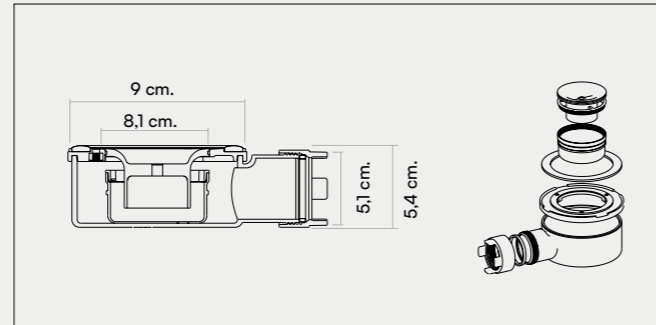

DOMO VERTICAL

Smart
Frame
Evolution
Angular
Maui
Bali
Capri

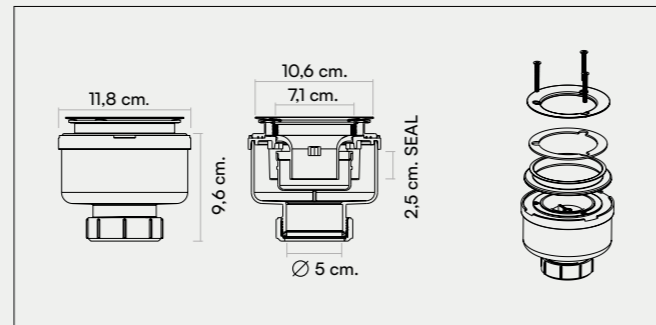

IGLU

Nassau
Fiji

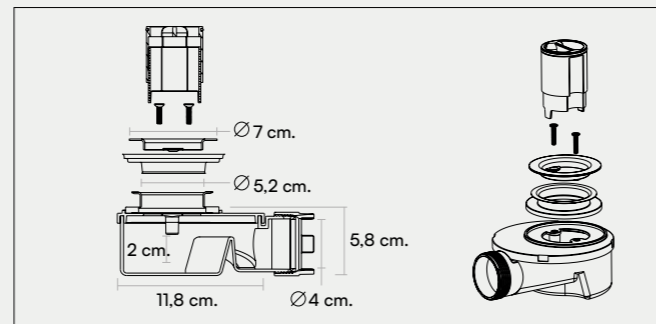

BLOCK

Side
West

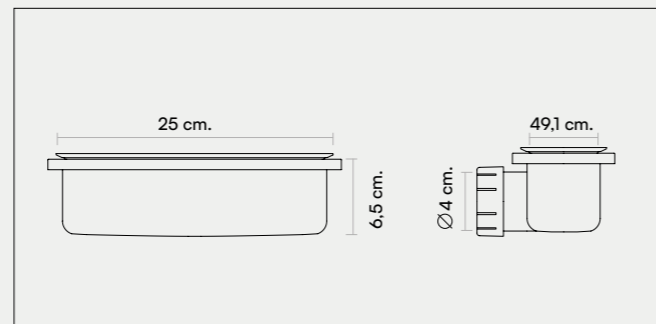

ADAPTABLE AL ESPACIO ADAPTABLE TO THE SPACE ADAPTABLE À L'ESPACE ADATTABILE ALLO SPAZIO RAUMANPASSUNGSFÄHIG

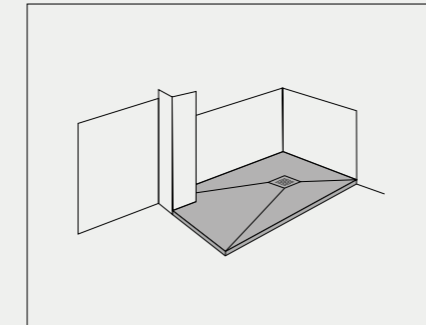

Corte a medida del plato de ducha.
Custom cut on the shower tray.
Coupe personnalisée dans le receveur de douche.
Taglio personalizzato del piatto doccia.
Duschwannen- Schnitt nach Massangabe.

ZONA DE SECADO RYING AREA ZONE DE SÉCHAGE AREA DI ASCIUGATURA TROCKNUNGSBEREICH

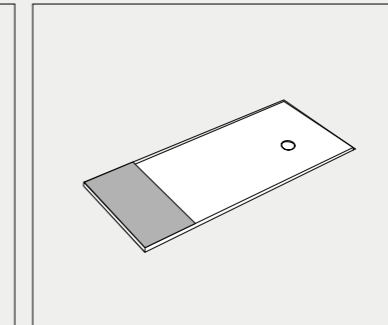

Pieza plana anexa al plato de ducha.
Flat piece attached to the shower tray.
Pièce plate annexée au receveur de douche.
Pezzo piano attaccato al piatto doccia.
An der Duschwanne angesetztes Flachstück.

REJILLA GRID GRILLE GRIGLIA ABFLUSSGITTER

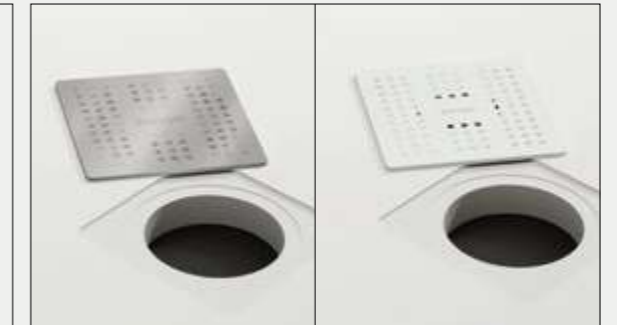

Rejilla personalizable en inox y en nuestros colores estándar.
Customisable stainless steel grids in our standard colours.
Grille acier inoxydable personnalisables dans nos couleurs standard.
Griglia personalizzabili in acciaio inox nei nostri colori standard.
Personalisierter abflaugitter in inox und in unseren standard farben.

INFORMACIÓN TÉCNICA TECHNICAL INFORMATION INFORMATION TECHNIQUE INFORMAZIONE TECNICA TECHNISCHE INFORMATION



Antideslizante
Anti-slip
Antidérapant
Antiscivolo
Rutschhemmend



Antibacteriano
Antibacterial
Antibactérien
Antibatterico
Antibakteriell



Sifón accesible
Accessible siphon
Siphon accessible
Scarico accessibile
Sifon zugänglich



* Adaptable al espacio
Adaptable to the space
Adaptable à l'espace
Adattabile allo spazio
Raumanpassend



Masa Coloreada
Coloured Body
Coloré dans la masse
Colorato in massa
Eingefärbte Masse



Fácil limpieza
Easy cleaning
Nettoyage facile
Facile pulizia
Leichte Reinigung



Garantía 3 años
Warranty 3 years
Garantie 3 ans
Garanzia 3 anni
3 Jahre Garantie

* Only Gel Coat

ES Plato de ducha incluye:
rejilla, embalaje, instrucciones
de montaje y válvula sifónica.

EN Shower tray includes:
grid, packaging, assembly
instructions and shower tray
waste.

FR Le receveur de douche
includ: grille, emballage,
instructions de montage et
bonde.

IT PII piatto include: la piletta
doccia sifonata, griglia inox,
imballo in cartone, istruzioni di
montaggio.

DE Duschwanne enthält:
Abflussgitter, Verpackung,
Montageanleitungen und
Abflusssifon/Ventil.

